

High-precision analog I/O terminal
for USB2.0

AIO-160802AY-USB



* Specifications, color and design of the products are subject to change without notice.

Features

Input 10μsec/ch, 8ch, output 10μsec, 2ch, 16bit resolution

Equipped with the analog input (10μsec/ch, 16bit, 8ch), analog output (10μsec, 16bit, 2ch) and digital I/O (4ch each, LVTTTL level)

Compatible to USB1.1/USB2.0 and not necessary to power this product externally as the bus power is used.

Compatible to USB1.1/USB2.0 and capable to achieve high speed transfer at HighSpeed (480 Mbps). Not necessary to power this product externally as the bus power of USB is used.

Equipped with the buffer memory (1K data) which can be used in either FIFO or ring format

This product includes buffer memory (1K data each for analog input and output) which can be used in either FIFO or ring format. You can perform analog I/O in the background, independent of software and the current status of the PC.

Windows compatible driver libraries are attached.

Using the attached driver library API-USBP(WDM) makes it possible to create applications of Windows. In addition, a diagnostic program by which the operations of hardware can be checked is provided.

Sampling can be driven by a clock or by various triggers

Sampling can be started and stopped by software or by an external trigger (timing controlled by an externally input control signal).

The sampling period can be controlled by the internal clock (high-precision timer included on the board) or by an external clock (externally input control signal).

Terminal connector facilitating wiring

Wiring is easy as the terminal connector (screw type) is used.

Software-based calibration function

Calibration of analog input/output can be all performed by software. Apart from the adjustment information prepared before shipment, additional adjustment information can be stored according to the use environment.

This product is a USB2.0 compatible terminal module that extends the analog I/O function of USB port of PCs. 8ch/16bits analog inputs and 2ch/16bits analog outputs are employed and signal lines can be directly connected to the screw terminals in the system. Compact design to match Note PCs and excellent in mobility as operation is powered by USB bus. This product accompanies Windows driver and full-fledged data logger software "C-LOGGER".

Possible to be used as a data recording device for MATLAB, with dedicated libraries.

Specification

(1/2)

Item	Specification
Analog input	
Isolated specification	Unisolated
Input type	Single-Ended Input
Number of input channels	8ch
Input range	Bipolar ±10V
Maximum input rating	±20V
Input impedance	1MΩ or more
Resolution	16bit
Non-Linearity error	±12LSB
Conversion speed	10μsec/ch (Max.) *3
Buffer memory	1K data *8
Conversion start trigger	Software / external trigger
Conversion stop trigger	Number of sampling times / external trigger/software
External start signal	LVTTTL level (Selecting one of the rising / falling / signal edge input to the DI00-pin by the software)
External stop signal	LVTTTL level (Selecting one of the rising / falling / signal edge input to the DI01-pin by the software)
External clock signal	LVTTTL level (Selecting the rising / falling to the DI02-pin by the software)
Analog output	
Isolated specification	Unisolated
Number of output channels	2ch
Output range	Bipolar ±10V
Absolute max. output current	±1mA
Output impedance	1Ω or less
Resolution	16bit
Non-Linearity error	±12LSB
Conversion speed	10μsec (Max.) *3
Buffer memory	1K data
Conversion start trigger	Software / external trigger
Conversion stop trigger	Number of sampling times / external trigger/software
External start signal	LVTTTL level (Selecting one of the rising / falling / signal edge input to the DI00-pin by the software)
External stop signal	LVTTTL level (Selecting one of the rising / falling / signal edge input to the DI01-pin by the software)
External clock signal	LVTTTL level (Selecting the rising / falling to the DI02-pin by the software)

(2/2)

Item	Specification
Digital I/O	
Number of input channels	Unisolated input 4ch (LVTTTL positive logic) *4*5
Number of output channels	Unisolated output 4ch (LVTTTL positive logic)
USB	
Bus specification	USB Specification 2.0/1.1 standard
USB transfer rate	12Mbps (Full-speed), 480Mbps (High-speed) *6
Power supply	Bus power
Common section	
Connector	14 pin (screw-terminal) plug header
Number of terminals used at the same time	127 terminals (Max.) *7
Power consumption (Max.)	5VDC 450mA
Operating condition	0 - 50°C, 10 - 90%RH(No condensation)
Physical dimensions (mm)	64(W) x 62(D) x 24(H) (exclusive of protrusions)
Weight	90g (Not including the USB cable, attachment)
Attached cable	USB cable 1.8m
Compatible wires	AWG28 - 16

- *1 The non-linearity error means an error of approximately 0.1% occurs over the maximum range at 0°C and 50°C ambient temperature.
- *2 When using the signal source equipped with the high-speed operational amplifier
- *3 This numerical displays the conversion speed for A/D, D/A converter. The minimum executable sampling cycle depends on the operating condition of the terminal.
- *4 You cannot use both the DI00 / DI01 / DI02-pin of digital input feature and the external start / stop signal / external clock input simultaneously.
- *5 Each input accept TTL (5VDC) level signals.
- *6 The USB transfer speed depends on the host PC environment used (OS and USB host controller).
- *7 As a USB hub is also counted as one device, you cannot just connect 127 USB terminals.
- *8 If (the number of channels) x (the number of samples) ≤ 1024 data, a sampling with an A/D converter's conversion rate of 10μSEC/ch is available. However, the actual amount of data that can be stored in the buffer memory will decrease: one unit of data of the buffer memory is consumed per sampling as the internal status. The following is an image of the buffer memory:

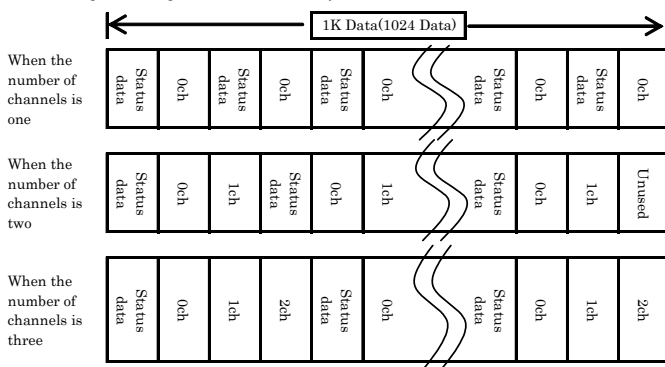

Consequently, the relationship among the number of channels, the number of samplings, and the sampling clock that can be sampled as described in the specification of the hardware is as follows:

Sampling channel	number of channel	number of sampling	Sampling clock
0ch	1	512	10μsec
0-1ch	2	341	20μsec
0-2ch	3	256	30μsec
0-3ch	4	204	40μsec
0-4ch	5	170	50μsec
0-5ch	6	146	60μsec
0-6ch	7	128	70μsec
0-7ch	8	113	80μsec

In the driver data software, the buffer memory is expanded to a 256 x 1024 data. However, if the number of samplings that exceeds the table above is specified, an adjustment of the sampling clock is required for the data transfer process from the device to the PC, which may prevent a sampling with the sampling clock above.

Support Software

Driver Library API-USBP(WDM) (Bundled)

It is the library software, and which supplies command of hardware produced by our company in the form of standard Win32 API function(DLL). Using programming languages supporting Win32API functions, such as Visual Basic and Visual C++ etc., you can develop high-speed application software with feature of hardware produced by our company. In addition, you can verify the operation of hardware using Diagnostic programs.

CONTEC provides download services (at <http://www.contec.com/apiusbp/>) to supply the updated drivers and differential files.

Further details may be found in the help within supplied CD-ROM or the homepage of our company.

< Operating environment >

OS Windows Vista, XP, Server 2003, 2000, Me, 98, etc..

Adaptation language Visual C++ .NET, Visual C# .NET, Visual Basic .NET, Visual C++, Visual Basic, Delphi, C++Builder, etc..

Data Logger Software C-LOGGER

(Supplied: Stored on the API-USBP(WDM) CD-ROM)

C-LOGGER is a data logger software program compatible with our analog I/O products. This program enables the graph display of recorded signal data, zoom observation, file saving, and dynamic transfer to the spreadsheet software "Excel". No troublesome programming is required.

CONTEC provides download services (at <http://www.contec.co.jp/clogger/>) to supply the updated drivers. For details, refer to the C-LOGGER Users Guide or our website.

< Operating environment >

OS Windows Vista, XP, Server 2003, 2000

Cable & Connector

Connector (Option)

14pin Screw Terminal Connector Set(6 pieces)
: CN6-Y14

Accessories

Accessories (Option)

Bracket for USB I/O Terminal products : BRK-USB-Y

* Check the CONTEC's Web site for more information on these options.

Packing List

USB terminal [AIO-160802AY-USB]...1

Interface connector plugs...2

First step guide ... 1

CD-ROM *1 [API-PAC(W32)] ...1

USB Cable(1.8m)...1

USB Cable Attachment...1

*1 The CD-ROM contains the driver software and User's Guide.

Block Diagram

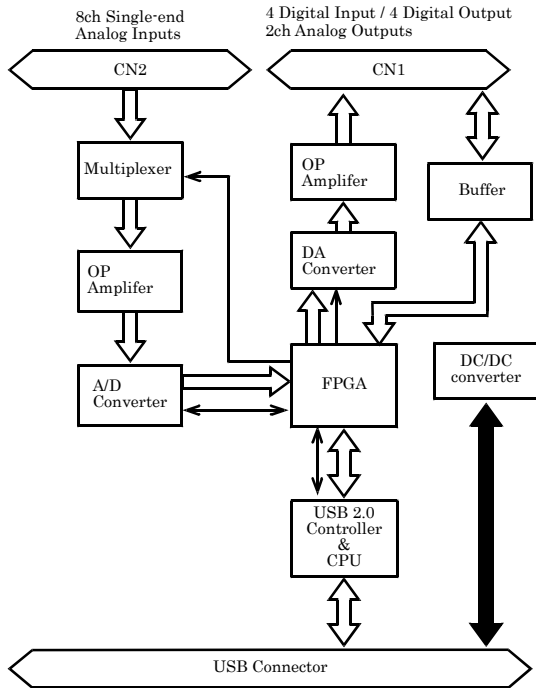

Physical Dimensions

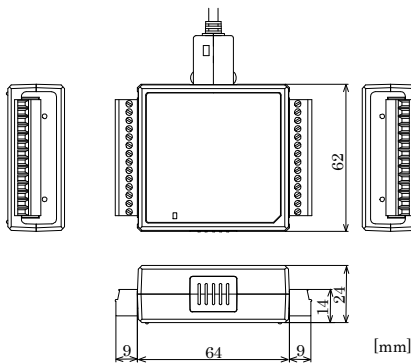

Cable connection

When connecting the product to an external device, you can use the supplied connector plug. For wiring, strip off approximately 9 - 10mm of the covered part of a wire rod and then insert it to the opening. After the insertion, secure the wire rod with screws. Compatible wires are AWG 28 - 16.

CAUTION

Removing the connector plug by grasping the cable can break the wire.

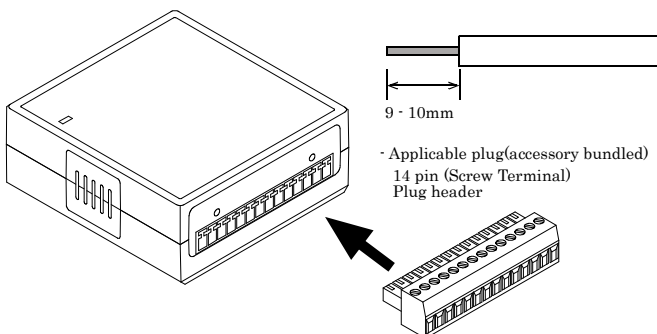

Using the On-terminal Connectors

Connecting a terminal to a Connector

To connect an external device to this terminal, plug the cable from the device into the interface connector (CN1, CN2) shown below.

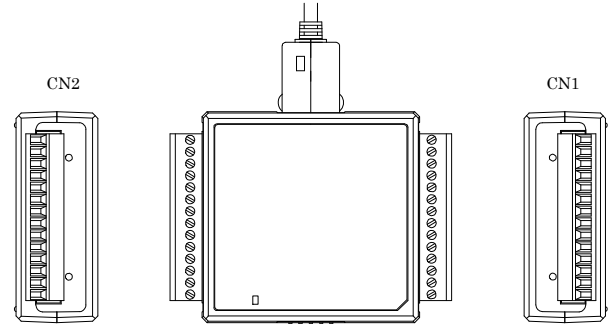

Connector Pin Assignment

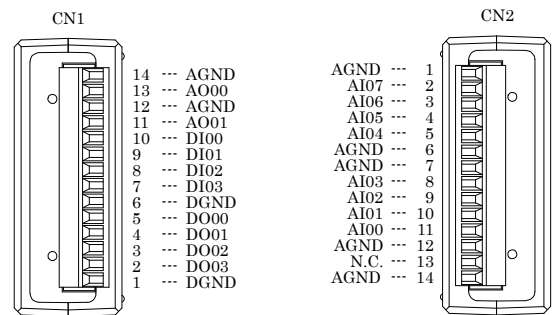

AI00 - AI07	Analog input signal. The numbers correspond to channel numbers.
AO00 - AO01	Analog output signal. The numbers correspond to channel numbers.
AGND	Common analog ground for analog I/O signals.
DI00 - DI03	Digital input signal.
DO00 - DO03	Digital output signal.
DGND	Common digital ground for digital I/O signals

Analog Input Signal Connection

Analog signal input types are divided into single-ended input and differential input. This product uses single-ended input fixed. The following examples show how to connect analog input signals using a flat cable and a shielded cable.

Single-ended Input

The following figure shows an example of flat cable connection. Connect separate signal and ground wires for each analog input channel on CN2.

Single-ended Input Connection (Flat Cable)

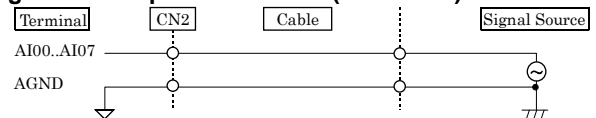

The following figure shows an example of shield cable connection. Use shielded cable if the distance between the signal source and product is long or if you want to provide better protection from noise. For each analog input channel, connect the core wire to the signal line and connect the shielding to ground.

Single-ended Input Connection (Shielded Cable)

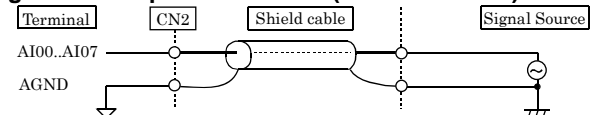

⚠ CAUTION

If the signal source contains over 1MHz signals, the signal may effect the cross-talk noise between channels.

If the product and the signal source receive noise or the distance between the product and the signal source is too long, data may not be input properly.

An input analog signal should not exceed the maximum input voltage (relate to the product analog ground). If it exceeds the maximum voltage, the product may be damaged.

Connect all the unused analog input channels to analog ground.

The signal connected to an input channel may fluctuate after switching of the multiplexer. In this case, the cable between this product and the signal source can be shortened or a buffer with a high-speed amplifier can be placed between the product and the signal source in order to reduce the fluctuation.

Analog Output Signal Connection

This section shows how to connect the analog output signal by using a flat cable or a shielded cable.

The following figure shows an example of flat cable connection. Connect the signal source and ground to the CN1 analog output.

Analog Output Connection (Flat Cable)

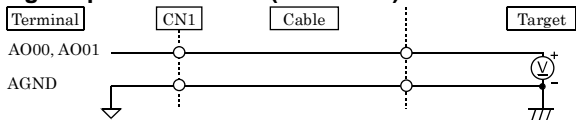

The following figure shows an example of shield cable connection. Use shielded cable if the distance between the signal source and product is long or if you want to provide better protection from noise. For each analog input channel on CN1, connect the core wire to the signal line and connect the shielding to ground.

Analog Output Connection (Shielded Cable)

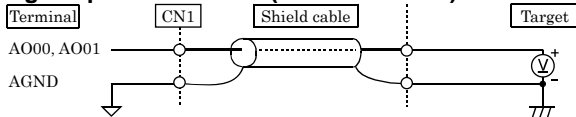

⚠ CAUTION

If this product or the connected wire receives noise, or the distance between this product and the target is long, data may not be outputted properly.

For analog output signal, the current capacity is □1mA (Max.). Check the specification of the connected device before connecting this product.

Do not short the analog output signal to analog ground, digital ground, and/or power line. Doing so may damage this product.

Do not connect an analog output signal to any other analog output, either on this product or on an external device, as this may cause a fault on this product.

When the USB cable is plugged, the analog output signal will be -10V.

Digital I/O signals Connection

The digital I/O signal can be used .as the control signal (external trigger input signal and sampling clock input signal, etc.), too. The following sections show examples. All the digital I/O signals are LVTTTL (3.3VDC) level signals.

Digital Input Connection

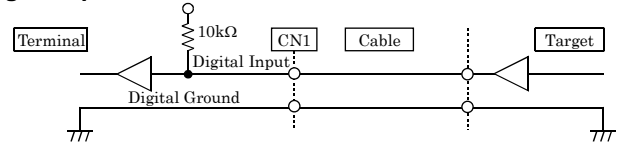

Digital Output Connection

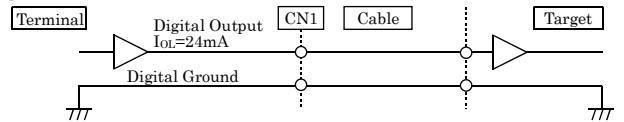

⚠ CAUTION

Do not short the output signals to analog ground, digital ground, and/or power line. Doing so may damage the terminal.

Each input accepts 5V TTL level signals.

The external trigger signal is fixed to the following signal location when using C-LOGGER.

DI00 : External start trigger signal input

* The external stop tripper and external clock cannot be used.