

Digital Input Terminal for USB2.0

DI-16TY-USB



* Specifications, color and design of the products are subject to change without notice.

Features

Unisolated TTL level input

DI-16TY-USB has the 16ch of unisolated TTL level input whose response speed is 200nsec.

Compatible to USB1.1/USB2.0 and not necessary to power this product externally as the bus power supply is used.

Compatible to USB1.1/USB2.0 and capable to achieve high speed transfer at HighSpeed (480 Mbps). Not necessary to power supply this product externally as the bus power of USB is used.

Surge absorption diodes are built in the input circuit for surge voltage protection.

DI-16TY-USB has a surge absorption diode connected to the +5V output pin at each input point to protect against surge voltages.

Windows compatible driver libraries are attached.

Using the attached driver library API-USBP(WDM) makes it possible to create applications of Windows. In addition, a diagnostic program by which the operations of hardware can be checked is provided.

Terminal connector facilitating wiring

Wiring is easy as the terminal connector (screw type) is used.

LabVIEW is supported by a plug-in of dedicated library VI-DAQ.

Using the dedicated library VI-DAQ makes it possible to make a LabVIEW application.

This product is a USB2.0-compatible terminal that expands the input function of a PC for digital signals. Being bus-powered, it does not need an external power supply.

DI-16TY-USB has the 16ch of unisolated TTL level input. In addition, it uses a protection circuit (surge protection) as its Input circuit as well as an easily-wired terminal connector.

Windows driver is bundled with this product.

Using the dedicated library VI-DAQ makes it possible to create each application for LabVIEW.

Specification

Item	Specifications
Input section	
Number of input signal points	16 points (1 common)
Input format	TTL-level input (Negative logic *1)
Input resistance	10kΩ (1 TTL load)
Surge protector	ESD Noise-Clipping Diodes NNCD6.8J (NEC) or equivalent
Response time	200nsec within *2
+5V output section	
Output voltage	4.75 - 5.25V
External supply capable current (Max.)	5VDC 100mA
Surge protector	ESD Noise-Clipping Diodes NNCD6.8J (NEC) or equivalent
USB	
Bus specification	USB Specification 2.0/1.1 standard
USB transfer rate	12Mbps (Full-speed), 480Mbps (High-speed) *3
Power supply	Bus power
Common	
Connector	14 pin (screw-terminal) plug header
Number of terminals used at the same time	127 terminals (Max.) *4
Current consumption (Max.)	5VDC 300mA
Operating conditions	0 - 50°C, 10 - 90%RH (No condensation)
Allowable distance of signal extension	Approx. 1.5m (depending on wiring environment)
Physical dimensions (mm)	64(W) x 62(D) x 24(H) (exclusive of protrusions)
Weight	70g (Not including the USB cable, attachment)
Attached cable	USB cable 1.8m
Compatible wires	AWG28 - 16

*1 Data "0" and "1" correspond to the High and Low levels, respectively.

*2 Response time of the input/ IC

*3 This depends on the host PC environment used (OS and USB host controller).

*4 As a USB hub is also counted as one device, you cannot just connect 127 USB terminals.

Physical Dimensions

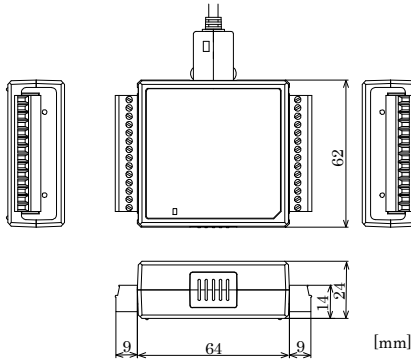

Component Locations

LED indicator

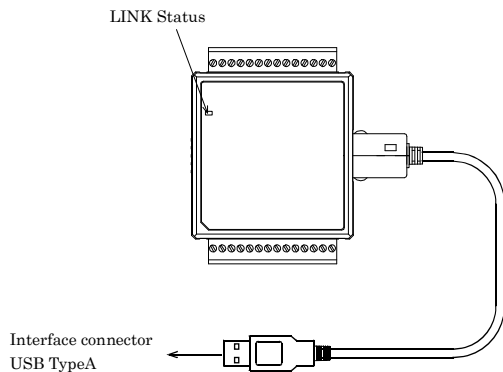

List of Status LED Functions

Name	Function	Indicator color	LED indicator
LINK Status	USB communication status	GREEN	ON : Communication established
			OFF : Communication unestablished
	PC connection status		ON : PC communication established
			OFF : PC communication unestablished

Support Software

Driver Library API-USBP(WDM) (Bundled)

It is the library software, and which supplies command of hardware produced by our company in the form of standard Win32 API function(DLL). Using programming languages supporting Win32API functions, such as Visual Basic and Visual C++ etc., you can develop high-speed application software with feature of hardware produced by our company. In addition, you can verify the operation of hardware using Diagnostic programs.

< Operating environment >

OS Windows Vista, XP, Server 2003, 2000, Me, 98

Adaptation language Visual Basic, Visual C++, Visual C#, Delphi, C++ Builder

Data acquisition VI library for LabVIEW VI-DAQ (Available for downloading (free of charge) from the CONTEC web site.)

This is a VI library to use in National Instruments LabVIEW. VI-DAQ is created with a function form similar to that of LabVIEW's Data Acquisition VI, allowing you to use various devices without complicated settings. See <http://www.contec.com/vidaq/> for details and download of VI-DAQ.

Cable & Connector

Connector (Option)

14pin Screw Terminal Connector Set (6 pieces)
: CN6-Y14

* Check the CONTEC's Web site for more information on these options.

Accessories

Accessories (Option)

Bracket for USB I/O Terminal products : BRK-USB-Y

* Check the CONTEC's Web site for more information on these options.

Packing List

USB terminal [DI-16TY-USB] ...1
Interface connector plugs ...2
First step guide ...1
CD-ROM *1 [API-USBP(WDM)] ...1
USB Cable (1.8m) ...1
USB Cable Attachment ...1

*1 The CD-ROM contains the driver software and User's Guide.

Using the On-terminal Connectors

Connecting a terminal to a Connector

To connect an external device to this terminal, plug the cable from the device into the interface connector (CN1, CN2) shown below.

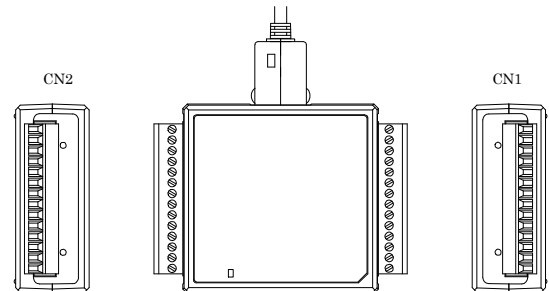

Connector Pin Assignment

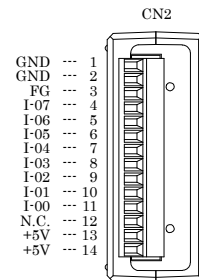
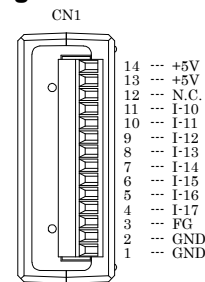

I-00 - I-17	16 input signal pins. Connect output signals from the external device to these pins.
+5V	This pin outputs power at +5 V. Max. electrical current is 100mA.
GND	This pin is connected to the USB-pin's GND.
FG	This pin is connected to the Frame Ground of PC.
N.C.	This pin is left unconnected.

Cable connection

When connecting the product to an external device, you can use the supplied connector plug.
For wiring, strip off approximately 9 - 10mm of the covered part of a wire rod and then insert it to the opening. After the insertion, secure the wire rod with screws. Compatible wires are AWG 28 - 16.

⚠ CAUTION

Removing the connector plug by grasping the cable can break the wire.
When connecting the connector plug to the product, be sure to insert it in the interior.

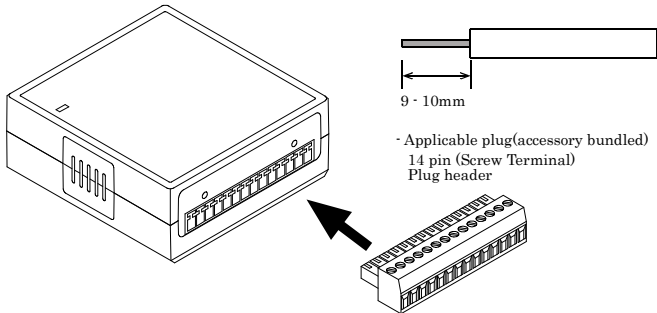

Connecting Input Signals

Input Circuit

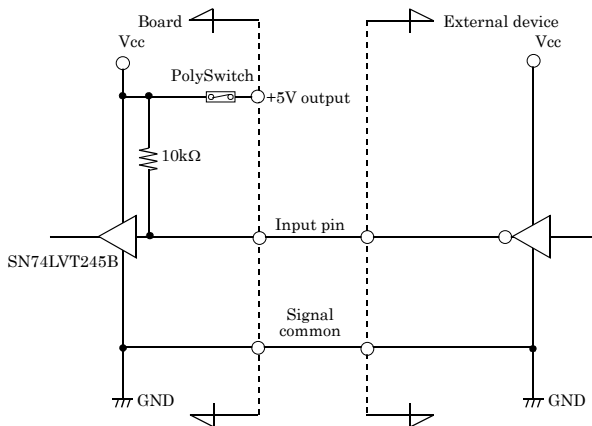

- * Input pin represent I-xx.
- * One PolySwitch is connected to all of the +5V output pins.

The input circuit of this product is illustrated in the above figure. External digital signals given to signal inputs are TTL levels. The individual input signals are passed to the personal computer as active low signals. As each of the signal inputs is pulled up internally, the output of a relay contact or semiconductor switch can be connected directly between the signal input and the signal common pin. Surge absorption diodes are connected to the input circuit.

Connecting a Switch

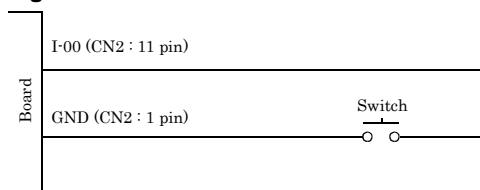

When the switch is ON, the corresponding bit contains 1.
When the switch is OFF, by contrast, the bit contains 0.

A Protection Function of the +5V Outputs

A protection function, which prevents excessive current flow from the +5V outputs, is attached to this terminal. In case of accidental short of the +5V output and GND, for example, the function works, and the terminal operation may become impossible temporarily. In such a case, you should turn the PC off and wait for several minutes before you use the terminal again.

Block Diagram

