

Isolated Digital I/O Terminal
for USB2.0

DIO-0808LY-USB



* Specifications, color and design of the products are subject to change without notice.

Features

Opto-coupler isolated input (supporting current sink output) and opto-coupler isolated open-collector output (current sink type)

This product has the opto-coupler isolated input 8 channels (supporting current sink output) and opto-coupler isolated open collector output (current sink type) 8 channels whose response speed is 300μsec. Supporting driver voltages of 12 - 24 VDC for I/O. (12 - 24VDC external circuit power supply is required separately.)

Compatible to USB1.1/USB2.0 and not necessary to power this product externally as the bus power is used.

Compatible to USB1.1/USB2.0 and capable to achieve high speed transfer at HighSpeed (480 Mbps).

Opto-coupler bus isolation

As the USB (PC) is isolated from the input and output interfaces by opto-couplers, this product has excellent noise performance.

Output circuits include zener diodes for surge voltage protection and poly-switches for overcurrent protection.

Zener diodes are connected to the output circuits to protect against surge voltages. Similarly, polyswitches are fitted to each group of 8channels outputs for over-current protection. The output rating is max. 35VDC, 100mA per channel.

Windows compatible driver libraries are attached.

Using the attached driver library API-USBP(WDM) makes it possible to create applications of Windows. In addition, a diagnostic program by which the operations of hardware can be checked is provided.

Easy-to-wire terminal connector adopted

Adoption of terminal connector (with screws) enables to achieve easy wiring.

LabVIEW is supported by a plug-in of dedicated library VI-DAQ.

Using the dedicated library VI-DAQ makes it possible to create each application for LabVIEW.

This product is a USB 2.0 compliant terminal that extends the digital signal I/O functions of a PC. This product is a 12 - 24VDC opto-coupler isolated type that does not require external power with input 8 channels and open-collector output 8 channels. In addition, output transistor protection circuit (surge voltage protection and overcurrent protection) are provided. Windows driver is bundled with this product.

Possible to be used as a data recording device for LabVIEW, with dedicated libraries.

Specification

Item	Specifications
Input section	
Number of input signal points	8 points (1 common)
Input format	Opto-isolated input (Compatible with current sink output) (Negative logic*1)
Input resistance	4.7 kΩ
Input ON current	2.0mA or more
Input OFF current	0.16mA or less
Response time	300μsec within *2
Output section	
Number of output signal points	8 points (1 common)
Output format	Opto-isolated open collector output (current sink type) (Negative logic*1)
Output rating	Output voltage 35VDC (Max.) Output current 100mA (per point) (Max.)
Residual voltage with output on	0.5V or less (Output current≤50mA), 1.0V or less (Output current≤100mA)
Surge protector	Zener diode RD47FM(NEC) or equivalent
Response time	300μsec within *2
USB	
Bus specification	USB Specification 2.0/1.1 standard
USB transfer rate	12Mbps (Full-speed), 480Mbps (High-speed) *3
Power supply	Bus power
Common	
Connector	14 pin (screw-terminal) plug header
Number of terminals used at the same time	127 terminals (Max.) *4
Dielectric strength	1000Vrms
External circuit power supply *5	12 - 24VDC (±10%)
Current consumption (Max.)	5VDC 250mA
Operating conditions	0 - 50°C, 10 - 90%RH (No condensation)
Allowable distance of signal extension	Approx. 50m (depending on wiring environment)
Physical dimensions (mm)	64(W) x 62(D) x 24(H) (exclusive of protrusions)
Weight	70g (Not including the USB cable, attachment)
Attached cable	USB cable 1.8m
Compatible wires	AWG28 - 16

*1 Data "0" and "1" correspond to the High and Low levels, respectively.

*2 The opto-coupler's response time comes.

*3 This depends on the host PC environment used (OS and USB host controller).

*4 As a USB hub is also counted as one device, you cannot just connect 127 USB terminals.

*5 External circuit power supply is required separately.

Support Software

Driver Library API-USBP(WDM) (Bundled)

It is the library software, and which supplies command of hardware produced by our company in the form of standard Win32 API function(DLL). Using programming languages supporting Win32API functions, such as Visual Basic and Visual C++ etc., you can develop high-speed application software with feature of hardware produced by our company. In addition, you can verify the operation of hardware using Diagnostic programs. CONTEC provides download services (at <http://www.contec.com/apiusbp/>) to supply the updated drivers and differential files. Further details may be found in the help within supplied CD-ROM or the homepage of our company.

< Operating environment >

OS Windows Vista, XP, Server 2003, 2000, Me, 98
Adaptation language Visual Basic, Visual C++, Visual C#, Delphi, C++ Builder

Data acquisition VI library for LabVIEW VI-DAQ (Available for downloading (free of charge) from the CONTEC web site.)

This is a VI library to use in National Instruments LabVIEW. VI-DAQ is created with a function form similar to that of LabVIEW's Data Acquisition VI, allowing you to use various devices without complicated settings. See <http://www.contec.com/vidaq/> for details and download of VI-DAQ.

Cable & Connector

Connector (Option)

14pin Screw Terminal Connector Set(6 pieces) : CN6-Y14

Accessories

Accessories (Option)

Bracket for USB I/O Terminal products : BRK-USB-Y

* Check the CONTEC's Web site for more information on these options.

Packing List

USB terminal [DIO-0808LY-USB]...1
Interface connector plugs...2
First step guide...1
CD-ROM *1 [API-USBP(WDM)]...1
USB Cable(1.8m)...1
USB Cable Attachment...1

*1 The CD-ROM contains the driver software and User's Guide.

Block Diagram

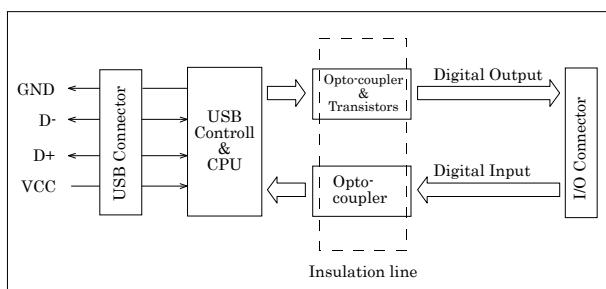

Physical Dimensions

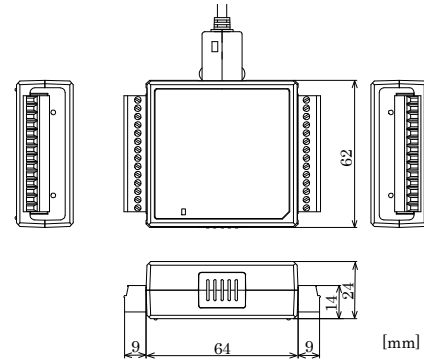

Name of each parts

LED indicator

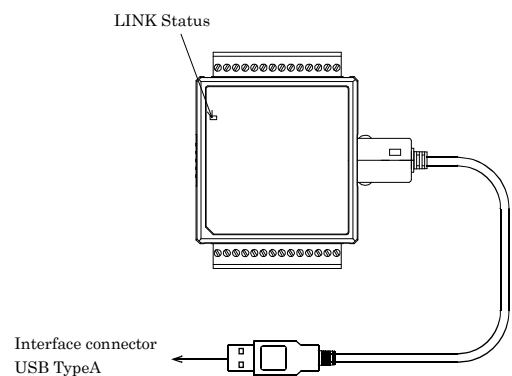

List of Status LED Functions

Name	Function	Indicator color	LED indicator
LINK Status	USB communication status	GREEN	ON : Communication established
			OFF : Communication unestablished
	PC connection status		ON : PC communication established
			OFF : PC communication unestablished

How to connect the connectors

Connecting a terminal to a Connector

To connect an external device to this terminal, plug the cable from the device into the interface connector (CN1, CN2) shown below.

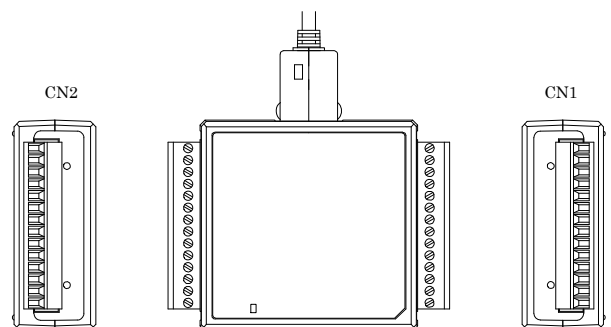

Connector Pin Assignment

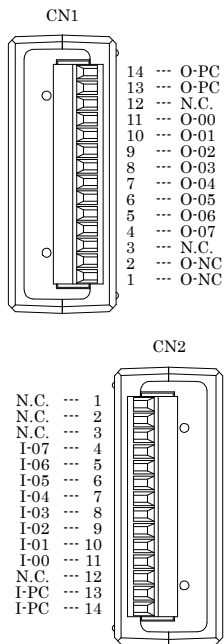

I-00 - I-07	8 input signal pins. Connect output signals from the external device to these pins.
O-00 - O-07	8 output signal pins. Connect these pins to the input signal pins of the external device.
I-PC	Connect the positive side of the external power supply. These pins are common to 8 input signal pins.
O-PC	Connect the positive side of the external power supply. These pins are common to 8 output signal pins.
O-NC	Connect the negative side of the external power supply. These pins are common to 8 output signal pins.
N.C.	This pin is left unconnected.

Cable connection

When connecting the product to an external device, you can use the supplied connector plug. For wiring, strip off approximately 9 - 10mm of the covered part of a wire rod and then insert it to the opening. After the insertion, secure the wire rod with screws. Compatible wires are AWG 28 - 16.

⚠ CAUTION

Removing the connector plug by grasping the cable can break the wire.

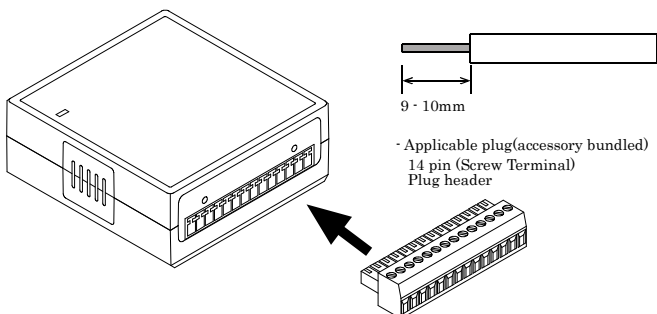

Input Signal Connection

Input Circuit

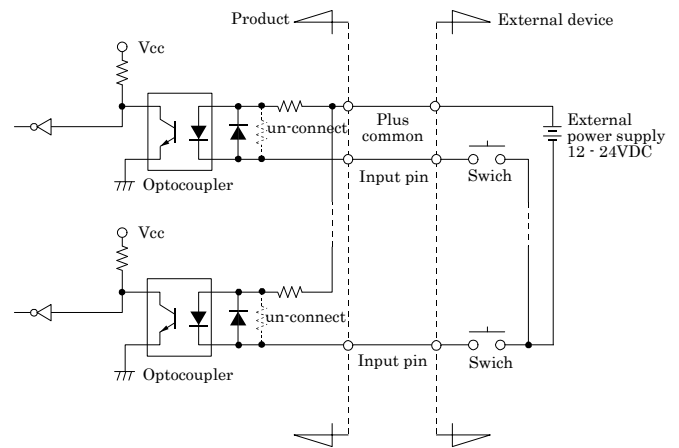

* Input pin represent I-xx.

The input circuit of this product is illustrated in the image above. It is connected to devices such as switch and transistor output devices, which can be powered by an electric current. The ON/OFF state of a device that can be powered by an electric current is entered as a digital value. The input channels are to be connected with current sinking output signals. Driving these opto-isolated circuits require an additional power supply isolated from the PC system. When a 12VDC external power is used, each input channel will consume about 2.6mA current; when a 24VDC external power supply is selected, each input channel will consume about 5.1mA current.

Connecting a Switch

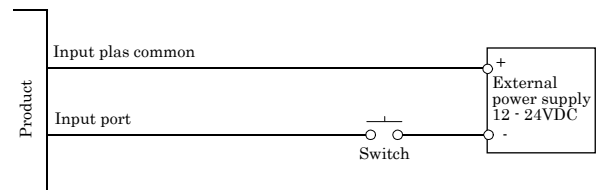

When the switch is ON, the corresponding bit contains 1.
When the switch is OFF, by contrast, the bit contains 0.

Output Signal Connection

Output Circuit

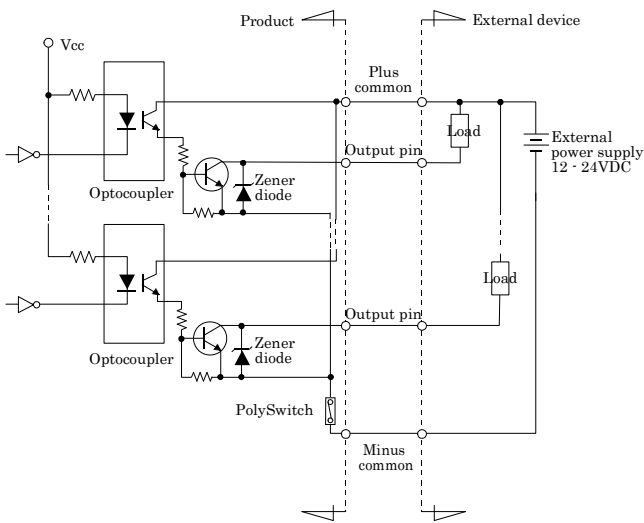

* Output pin: O-xx

The output circuit of this product is illustrated the image above. The signal output section is an opto-isolated, open-collector output (current sink type). Driving the output section requires an external power supply.

The rated output current per channel is 100 mA at maximum. The output section can also be connected to a TTL level input as it uses a low-saturated transistor for output. The residual voltage (low-level voltage) between the collector and emitter with the output on is 0.5 V or less at an output current within 50 mA or at most 1.0 V at an output current within 100 mA. A zener diode is connected to the output transistor for protection from surge voltages. A PolySwitch-based over-current protector is provided for every eight output transistors. When the over-current protector works, the output section of the product is temporarily disabled. If this is the case, turn of the power to the PC and the external power supply and wait for a few minutes, then turn them on back.

CAUTION

When the PC is turned on, all output are reset to OFF.

Example of Connection to LED

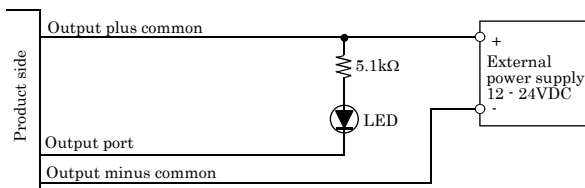

When "1" is output to a relevant bit, the corresponding LED comes on.
When "0" is output to the bit, in contrast, the LED goes out.

Example of Connection to TTL Level Input

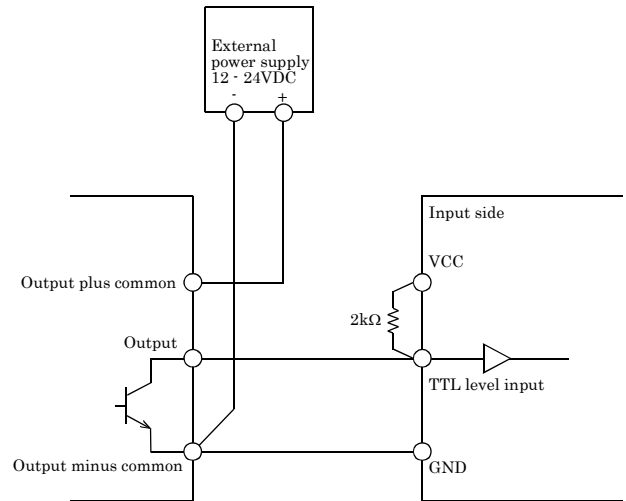

Connecting the Sink Type Output and Sink Output Support Input

The following example shows a connection between a sink type output (output side) and a sink output support input (input side). Use this sample connection as a reference when connecting more than one of this product together.

