

Bi-Directional Digital I/O Board  
for PCI Express

DIO-48D-PE



\* Specifications, color and design of the products are subject to change without notice.

Features

**This board can be used to TTL-level input/output 48 points bi-directional digital corresponding to the equivalence to the i8255 mode 0.**

This board has up to 48 unisolated TTL-level input/output channels whose response speed is 200nsec that is powered by to the equivalence to the mode 0 of i8255 device for general-purpose. You can select the input/output by the application software in eight signals units (in four signals unit for some inputs/outputs).

**You can use up to 48channels of the input signals as interrupt events.**

You can use up to 48channels of the input signals as interrupt events and also disable or enable the interrupt in bit units and select the edge of signals, at which to generate an interrupt.

**This product has a digital filter function to prevent wrong recognition of input signals from carrying noise or a chattering.**

This product has a digital filter function to prevent wrong recognition of input signals by noise or chattering is provided. All input terminals can be added a digital filter, and the setting can be performed by software.

**Windows/Linux compatible driver libraries are attached.**

Using the attached driver library API-PAC(W32) makes it possible to create applications of Windows/Linux. In addition, a diagnostic program by which the operations of hardware can be checked is provided.

**Functions are compatible with PCI compatible board DIO-48D2-PCI.**

The functions same with PCI compatible board DIO-48D2-PCI are provided. In addition, as there is compatibility in terms of connector shape and pin assignments, it is easy to migrate from the existing system.

**LabVIEW is supported by a plug-in of dedicated library VI-DAQ.**

Using the dedicated library VI-DAQ makes it possible to create each application for LabVIEW.

This product is a PCI Express bus-compliant interface board that extends the input/output function of bi-directional digital signal. This board has up to 48 unisolated TTL-level input/output channels that is powered by the equivalence to the mode 0 of i8255 chips, and you can use up to 48 channels of the input signals as interrupt inputs. You can select the input/output by the application software in eight signals units (in four signals unit for some inputs/outputs). Additionally, the digital filter function is equipped with this product. Windows/Linux driver is bundled with this product.

Using the dedicated library VI-DAQ makes it possible to create each application for LabVIEW.

Specification

Item	Specification
I/O	
I/O format	Unisolated TTL-level I/O (Positive logic) *1
Number of I/O channels	48 channels (all available for interrupts)
Pull-up resistance	10kΩ
Interrupt	48 interrupt input signals are arranged into a single output of interrupt signal INTA. An interrupt is generated at the rising edge (LOW-to-HIGH transition).
Response time	Within 200nsec
Rated output current	I <sub>OL</sub> =24mA (Max.) I <sub>OH</sub> =-15mA (Max.)
Common	
External supply capable current (Max.)	5VDC 350mA
I/O address	Any 32-byte boundary (Common to I/O part)
Power consumption (Max)	3.3VDC 1000mA
Operating condition	0 - 50°C, 10 - 90%RH (No condensation)
Allowable distance of signal extension	Approx. 1.5m (depending on wiring environment)
Bus specification	PCI Express Base Specification Rev. 1.0a x1
Dimension (mm)	169.33 (L) x 110.18(H)
Connector	
CN1	96 pin half pitch connector [F (female) type] PCR-E96LMD+ [mfd. by HONDA TSUSHIN KOGYO CO., LTD.] or equivalent to it
CN2,3	50 pin IC pitch pin header connector PS-50PE-D4T1-B1A [mfd.by JAE] or equivalent to it
Weight	140g

\*1 Data "1" and "0" correspond to the High and Low levels, respectively.

Board Dimensions

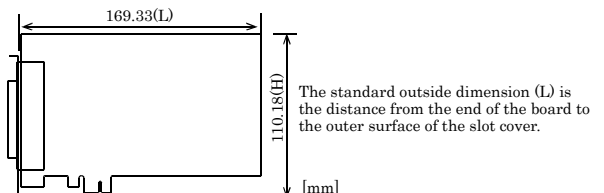

## Support Software

### Windows version of digital I/O driver API-DIO(98/PC) / API-DIO(WDM)

[Stored on the bundled CD-ROM driver library API-PAC(W32)]

The API-DIO(98/PC) is the Windows version driver library software that provides products in the form of Win32 API functions (DLL). Various sample programs such as Visual Basic and Visual C++, etc and diagnostic program useful for checking operation is provided.

< Operating environment >

OS Windows Vista, XP, Server 2003, 2000  
Adaptation language Visual Basic, Visual C++, Visual C#, Delphi, C++ Builder

You can download the updated version from the CONTEC's Web site (<http://www.contec.com/apipac/>). For more details on the supported OS, applicable language and new information, please visit the CONTEC's Web site.

### Linux version of digital I/O driver API-DIO(LNX)

[Stored on the bundled CD-ROM driver library API-PAC(W32)]

The API-DIO(LNX) is the Linux version driver software which provides device drivers (modules) by shared library and kernel version. Various sample programs of gcc are provided.

< Operating environment >

OS RedHatLinux, TurboLinux  
(For details on supported distributions, refer to Help available after installation.)

Adaptation language gcc

You can download the updated version from the CONTEC's Web site (<http://www.contec.com/apipac/>). For more details on the supported OS, applicable language and new information, please visit the CONTEC's Web site.

## Cable & Connector

### Cable(Optional)

Shield Cable with 96-Pin Half-Pitch Connectors at Both Ends  
: PCB96PS-0.5P (0.5m)  
: PCB96PS-1.5P (1.5m)

Flat Cable with 96-Pin Half-Pitch Connectors at Both Ends  
: PCB96P-1.5 (1.5m)

Shield Cable with 96-Pin Half-Pitch Connectors at One End  
: PCA96PS-0.5P (0.5m)  
: PCA96PS-1.5P (1.5m)

Flat Cable with 96-Pin Half-Pitch Connectors at One End  
: PCA96P-1.5 (1.5m)

Flat cable with single-ended connector for 50-pin  
: PCA50J-1.5 (1.5m)

### Connector(Optional)

Half-pitch 96-pin Female Connector Set (5 Pieces)  
: CN5-H96

## Accessories

### Accessories (Option)

Screw Terminal Unit (M3 x 96P) : EPD-96A \*1 \*2  
Screw Terminal Unit (M3.5 x 96P) : EPD-96 \*1  
Terminal Unit for Cables (M2.5 x 96P) : DTP-64(PC) \*1

\*1 PCB96P or PCB96PS optional cable is required separately.

\*2 "Spring-up" type terminal is used to prevent terminal screws from falling off.

\* Check the CONTEC's Web site for more information on these options.

## Packing List

Board [DIO-48D-PE] ... 1  
First step guide ... 1  
CD-ROM \*1 [API-PAC(W32)] ... 1  
Standard-sized bracket ... 1

\*1 The CD-ROM contains the driver software and User's Guide.

## How to connect the connectors

### Connector shape and optional cable connection

To connect an external device to this board, plug the cable from the device into the interface connector (CN1 or CN2 and CN3) shown below.

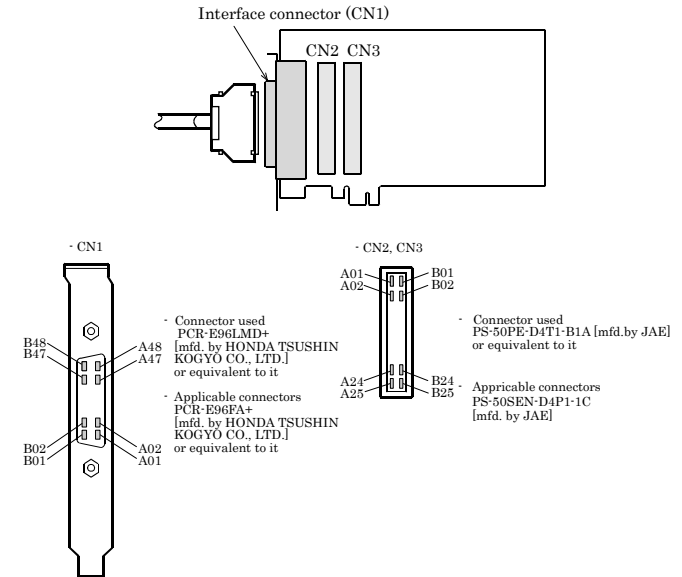

\* Please refer to page 2 for more information on the supported cable and accessories.

### CAUTION

CN2 and CN3 are designed assuming the connection to any other board or device in the same PC (system).

For connecting CN2 or CN3 to a device outside the PC, use an adjacent expansion slot as required.

The 96-pin connector (CN1) and 50-pin connectors (CN2 and CN3) are mutually exclusive. Use either of them at a time.

## Connector Pin Assignment

### Pin Assignments of Interface Connector (CN1)

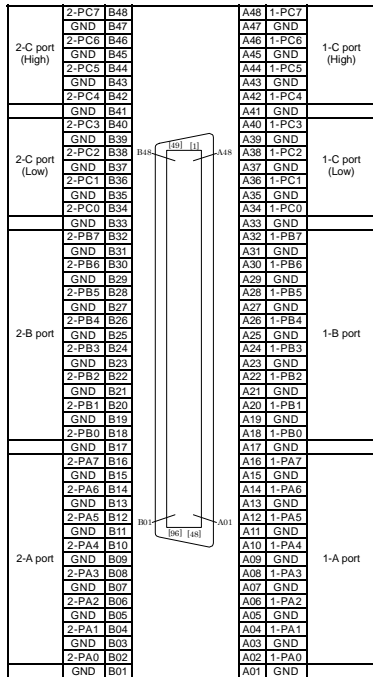

\* The numbers in square brackets [ ] are pin numbers designated by HONDA TSUSHIN KOGYO CO., LTD.

1-C port (High)	1-PC7 A01	B01 GND	2-C port (High)	2-PC7 A01	B01 GND
	1-PC6 A02	B02 GND		2-PC6 A02	B02 GND
	1-PC5 A03	B03 GND		2-PC5 A03	B03 GND
	1-PC4 A04	B04 GND		2-PC4 A04	B04 GND
	1-PC3 A05	B05 GND		2-PC3 A05	B05 GND
1-C port (Low)	1-PC2 A06	B06 GND	2-C port (Low)	2-PC2 A06	B06 GND
	1-PC1 A07	B07 GND		2-PC1 A07	B07 GND
	1-PC0 A08	B08 GND		2-PC0 A08	B08 GND
1-B port	1-PB7 A09	B09 GND	2-B port	2-PB7 A09	B09 GND
	1-PB6 A10	B10 GND		2-PB6 A10	B10 GND
	1-PB5 A11	B11 GND		2-PB5 A11	B11 GND
	1-PB4 A12	B12 GND		2-PB4 A12	B12 GND
	1-PB3 A13	B13 GND		2-PB3 A13	B13 GND
	1-PB2 A14	B14 GND		2-PB2 A14	B14 GND
	1-PB1 A15	B15 GND		2-PB1 A15	B15 GND
	1-PB0 A16	B16 GND		2-PB0 A16	B16 GND
1-A port	1-PA7 A17	B17 GND	2-A port	2-PA7 A17	B17 GND
	1-PA6 A18	B18 GND		2-PA6 A18	B18 GND
	1-PA5 A19	B19 GND		2-PA5 A19	B19 GND
	1-PA4 A20	B20 GND		2-PA4 A20	B20 GND
	1-PA3 A21	B21 GND		2-PA3 A21	B21 GND
	1-PA2 A22	B22 GND		2-PA2 A22	B22 GND
	1-PA1 A23	B23 GND		2-PA1 A23	B23 GND
	1-PA0 A24	B24 GND		2-PA0 A24	B24 GND
+5VDC	Vcc A25	B25 GND		Vcc A25	B25 GND

## Connecting I/O Signals

The I/O circuits of interface blocks of this board are illustrated in the below Figure. Signals are TTL levels and positive logic.

### I/O Circuit

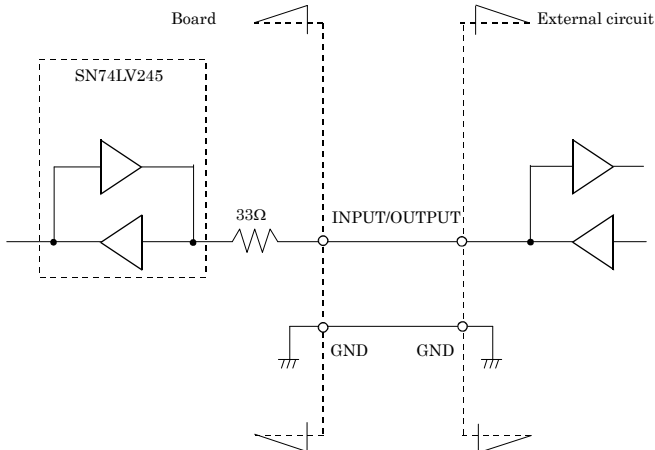

(\*) Only CN2 and CN3 has +5VDC output pin. Current to be able to supplied is within 350mA (total).

## Example of Connection

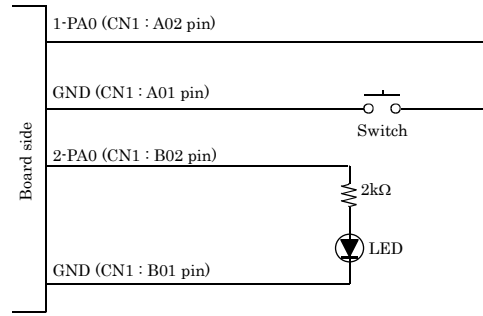

When switch is "ON", the corresponding bit is "0". When switch is "OFF" in contrast, the corresponding bit is "1".  
When "1" is output to a relevant bit, the corresponding LED comes on. When "0" is output to the bit, in contrast, the LED goes out.

## About the Protection Feature

The +5VDC output of the board is provided with a PolySwitch-based protection feature. If the +5VDC output is accidentally connected to GND, the protection feature works and it may disable the board temporarily. In that case, turn the PC off, wait for a few minutes, then turn the PC back on.

## Block Diagram

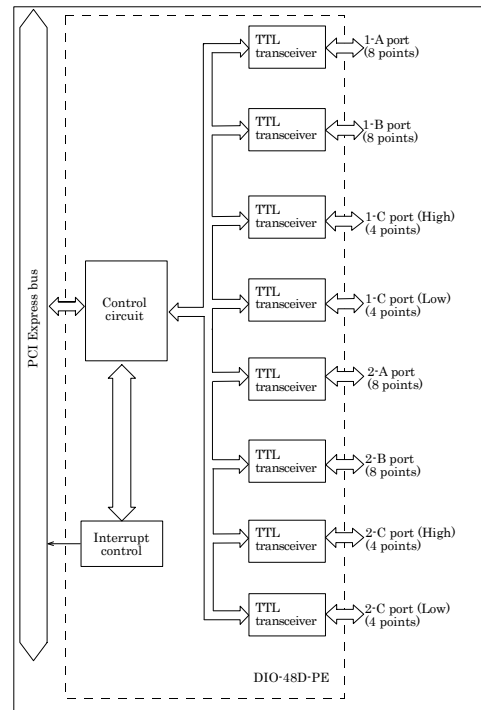

## Difference from DIO-48D2-PCI

The functions same with conventional product of DIO-48D2-PCI are provided with the DIO-48D-PE. In addition, as there is compatibility in terms of connector shape and pin assignments, it is easy to migrate from the existing system. So you can use the same operating procedures as DIO-48D2-PCI.

There are some differences in specifications as shown below.

	DIO-48D2-PCI	DIO-48D-PE
Power consumption	5VDC 600mA (Max.)	3.3VDC 1000mA (Max.)
Bus specification	32-bit, 33MHz, Universal key shapes supported (The 5V pin on the bus must supply 5V.)	PCI Express Base Specification Rev. 1.0a x1
Dimension (mm)	176.41(L) x 106.68(H)	169.33 (L) x 110.18(H)